

### CU Generator Packages

#### MrSteam CU Standard Features

- Stainless steel jacket prolongs life of unit
- Carbon steel pressure vessel meets ASME and National Board requirements for low-pressure operation
- Adherence to National and Local codes, and cULus listed
- All units are wired and pre-tested before shipping to assure all parts of the generator are working perfectly
- Specifically designed for commercial applications that require continuous or near continuous use so they are available to use all day.
- Steam-On-Demand maintains pre-selected temperatures utilizing minimum energy for maximum heat, instantly.
- One generator can operate up to two rooms.

#### Safety Features

- High pressure shutoff redundancies
- Corrosion-resistant Stainless steel heating elements
- ASME safety valve for emergency pressure venting
- Auxiliary Low Water cutoff with Manual Reset
- Acrylic Shield included to help prevent burns from coming into contact with the steam head.

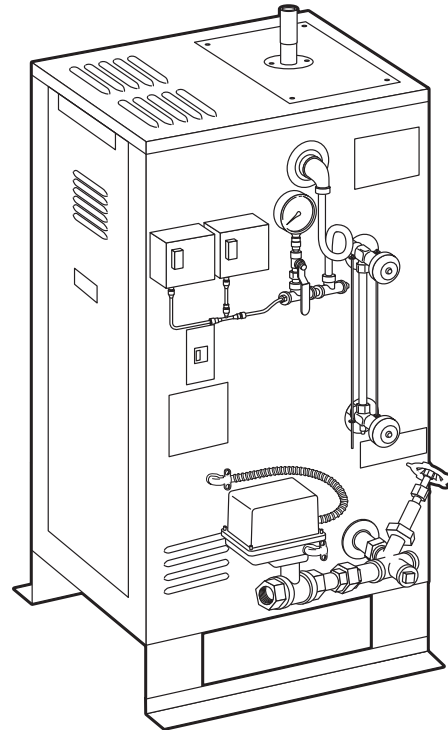

#### Required Plumbing

<b>Steam Outlet:</b>	1" NPT	
<b>Drain Line:</b>	1" NPT	
<b>Steam Head:</b>	¾" NPT	
<b>Water Supply:</b>	C0360-C1400	¼" NPT
	C2000 + up	½" NPT
<b>Safety Valve:</b>	C0360-C1400	¾" NPT
	C2500-3000	¾" NPT
	C2000	½" NPT
	C4500	1" NPT

Model No.	KW	Max Room Volume* (cu ft)	Water Inlet Size NPT	Generator Outlet Size, NPT	Dimensions (inches)			Shipping Wt. (lbs.)
					W	L	H	
C0360	9	400	1/4"	1"	20	30	38	230
C0500	12	500	1/4"	1"	20	30	38	230
C0750	18	750	1/4"	1"	20	30	38	230
C1000	24	1000	1/4"	1"	20	30	38	230
C1250	30	1250	1/4"	1"	20	30	38	230
C1400	36	1400	1/4"	1"	20	30	38	300
C2000	48	2000	1/2"	1"	24	33	44	330
C2500	60	2500	1/2"	1"	24	33	44	380
C3000	72	3000	1/2"	1"	24	33	44	390
C4500	108	4500	1/2"	1-1/2"	28	34	59	625

\*After taking into consideration all factors affecting resultant steam room volume including length, width & height of steam room and distance to generator, select proper Model CU generator. Consult with an architect, engineer, designer and/or contractor before making final selection.

**DIMENSIONS & CLEARANCE SPECIFICATIONS**

**IMPORTANT:**

**Minimum Clearance from Combustible Surfaces:**

- M** 1" above top of CU generator
- N** Front of CU generator suitable for alcove installation only.
- O** 1" from left side of CU generator.
- P** 16" from right side of CU generator.
- Q** Type of flooring: "C", suitable for combustible flooring.
- R** 1" from rear of CU generator.

For ease of servicing, MrSteam recommends a minimum of 36 inches of clearance all around the CU generator.

**Label Function**

- |                                      |   |
|--------------------------------------|---|
| <b>A</b> Steam Outlet                | <b>G</b> Pressure Gauge                                       |
| <b>B</b> Water Inlet                 | <b>H</b> Gauge Glass Assembly                                 |
| <b>C</b> Drain Outlet                | <b>I</b> Drain Valve  |
| <b>D</b> Automatic Blowdown Valve    | <b>J</b> Safety Valve   |
| <b>E</b> High Limit Pressure Control | <b>K</b> On/Off Switch  |
| <b>F</b> Operating Pressure Control  | <b>L</b> MM 150 Liquid Level Control (only CU2000 and larger) |

**C0360- C1400**

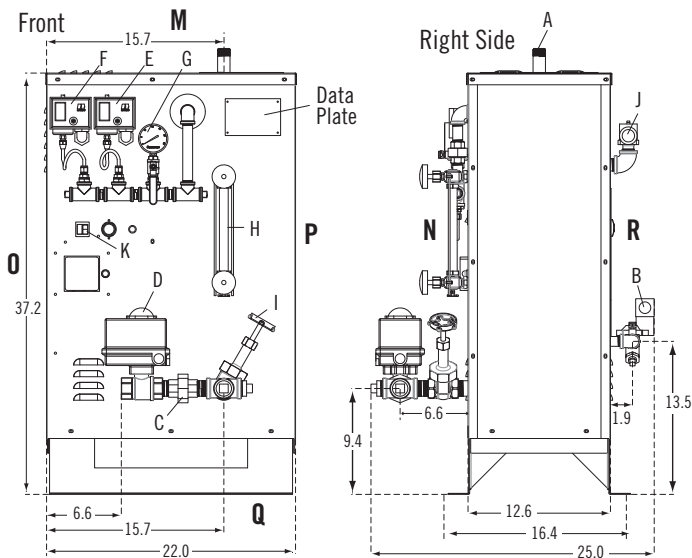

**C4500**

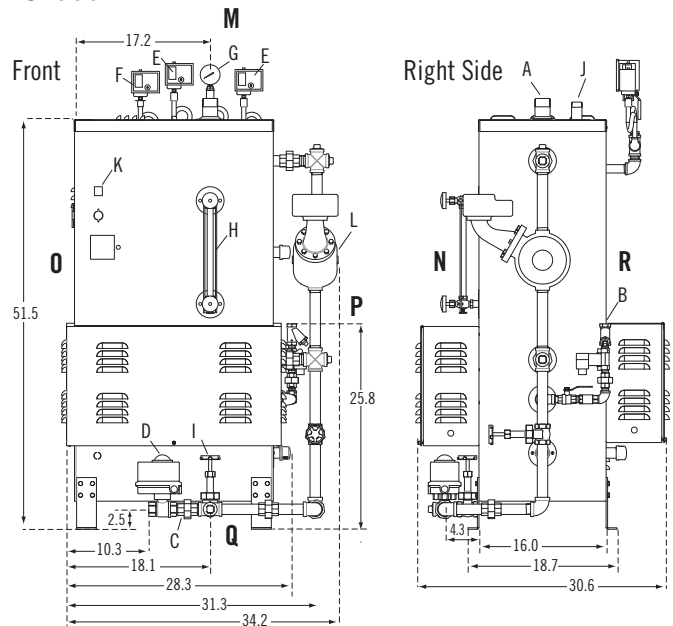

**C2000**

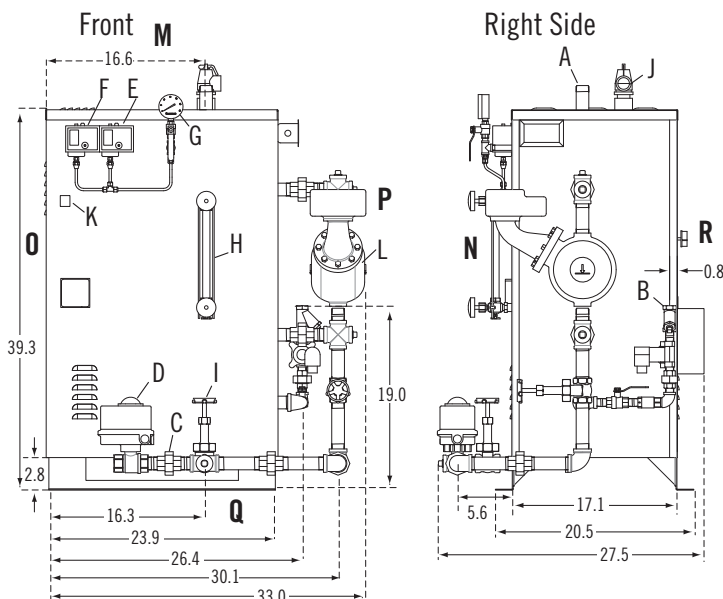

### Locating and Installing the Steam Generator Unit

- Select a location as near as practical to the steam room, within 25 feet. Typical locations include: Closets, supply rooms or maintenance areas.
- Do not install steambath generator inside the steam room
- Do not install steambath generators outside or wherever environmental conditions may affect the safety and/or performance of the generator
- Do not install steambath generator near flammable or corrosive materials or chemicals or in areas having a high concentration of chlorine
- Install steambath generator on a solid and level surface in the upright position only
- Provide ample clearance around the generator as listed in the IOM
- Provide unions as required to facilitate installation and disconnection of the generator.
- Locate the steam line, safety valve, drain valve, plumbing and steam head in a location where they will not come in contact with service personnel or bathers. These objects will get hot during operation and after shutdown while the boiler is still cooling down.
- Recommended to install boiler in a locked room that is accessible by only authorized personnel and not the general public.

### Power Wiring

1. Check power voltage. Confirm it is same voltage that is specified on the unit
2. Use minimum 90°C rated insulated copper conductors only, type THHN or equal sized in accordance with National Electrical Code and local electrical code for the Amps in Ampere Chart.
3. Connect suitably sized equipment grounding wire to ground terminal provided.
4. Install a separate circuit breaker between supply and unit provide a power supply disconnect within sight of the steam generator or one that is capable of being locked in the open position
5. An additional 120VAC line is required to run the controls inside the boiler if the transformer has not been added as a factory option.

### Electrical

All electrical wiring to be installed by a qualified licensed electrician in accordance with National Electrical Code and local electrical code.

AMPERAGE CHART							
Indicates Total Ampere Draw of Specific CU Model at Voltage & Phase Specified							
Model No.	kW	208V/1 PH	208V/3 PH	240V/1 PH	240V/3 PH	480V/3 PH	600V/3 PH
C0360	9	44	25	38	22	11	9
C0500	12	58	34	50	29	15	12
C0750	18	87	50	75	44	22	18
C1000	24	116	67	100	58	29	24
C1250	30	145	84	125	73	37	29
C1400	36	-	100	-	87	44	35
C2000	48	-	134	-	116	58	47
C2500	60	-	167	-	145	73	58
C3000	72	-	200	-	174	87	70
C4500	108	-	300	-	260	130	104

**IMPORTANT:** Use minimum 90° C insulated copper conductors only for field wiring sized in accordance with National and local electric Codes.

**NOTE:** Consult factory for other voltage/phase combinations. CU generators are suitable for 50/60 hz. Standard control circuit voltage for above V/PH combinations for United States, Canada and Mexico is 120 VAC. Exception: 220-240 VAC control circuit voltage is provided on non-domestic product where power voltage is 220-240 V/3 PH, 380V/3PH, 415V/3 PH, etc.

## Digital 1® Control Package

The Digital 1 Control maintains selected room temperature and features a high limit shut-off. Provides Steam-On-Demand® for consistent room temperature comfort and control.

### CU1-D1 KIT CONTENT

- Digital 1 Control (*factory installed on generator*)
- Digital 1 Sensor
- One ¾" Steam Solenoid Valve
- One ¾" Steamhead
- Acrylic Shield
- Sensor Cover

### CU2-D1 KIT CONTENT

For CU 2000 - 4500 serving one room using two steam solenoid valves and two steamheads.

- Digital 1 Control (*factory installed on generator*)
- Two ¾" Steam Solenoid Valves
- Two ¾" Steamheads
- Digital 1 Sensor
- Two Acrylic Shields, one for each steamhead
- Sensor Cover

### OPERATING PARAMETERS

- Operating Temperature Range 80-120°F (26.5 - 49°C)
- Backup Temperature shut off fixed at 130°F (54.5°C)

### BACKUP TEMPERATURE SHUT-OFF

- In the event room conditions or environment cause the temperature to reach 130 °F (54.5 °C) the Digital 1 Control will shut off power to the steam bath generator.
- The Digital 1 control will reset when the temperature in the room reaches normal operating range.

### TEMPERATURE SENSOR INSTALLATION

- Locate sensor on a wall inside the steam room five (5) feet above the floor
- Do NOT locate the Digital 1 sensors near or above the steamhead(s) as this may cause direct steam emission to interfere with steam room temperature regulation.
- Do NOT route sensor cable with power wiring, next to electric motors or any other location subject to electrical noise.

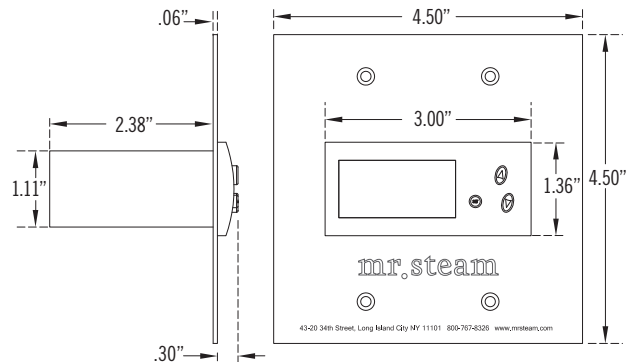

**FOR ILLUSTRATIVE PURPOSES ONLY. IMPORTANT NOTE: FOR SAFE AND TROUBLE FREE INSTALLATION** Before installation, visit [mrsteam.com](http://mrsteam.com) to download the Installation, Operation and Maintenance Manual or refer to the manual provided with the unit.

# CU Steamhead

- 3/4" NPT
- 100% solid brass
- Complete with polycarbonate Acrylic Shield
- Polished Chrome finish

### LOCATION AND INSTALLATION

1. For steam rooms constructed of tile, marble or similar non-porous heat-resistant materials for the enclosure, locate steam head 12 inches above steam room floor and install MrSteam PN 103985 acrylic shield on each steamhead.

**IMPORTANT:** For Steam rooms using acrylic, fiberglass or other non-heat resistant materials used for steam room enclosure, install each steamhead 20-30 inches above the floor.

2. Locate each steamhead away from bather seating area and away from traffic patterns as required to prevent incidental contact with steamhead or direct steam emissions.

3. **NOTE:** To preserve the steamhead finish, do not use wrench or other tools to tighten. Use of proper thread sealant and hand tightening is usually sufficient.

4. Apply a bead of silicone around the steamhead where it meets the wall as required to prevent moisture damage.

### ACRYLIC SHIELD

Apply a small bead of silicone in the grooves on the top and bottom of the steamhead. Place an Acrylic Shield (PN 103985) over the steamhead until the tabs engage the grooves in the steamhead.

**IMPORTANT:** Do not use with fragrance containing aldehydes. Acrylic Shield damage may result. MrSteam oils are approved for use with this acrylic shield.

**IMPORTANT NOTE:** Install steamhead with acrylic shield according to orientation illustrated above. Steam vents out of steam slots to left and right of steamhead.

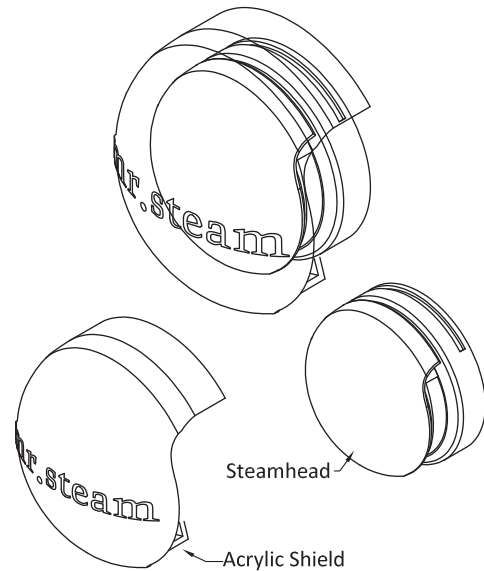

### STEAMHEAD/ACRYLIC SHIELD DIMENSIONS

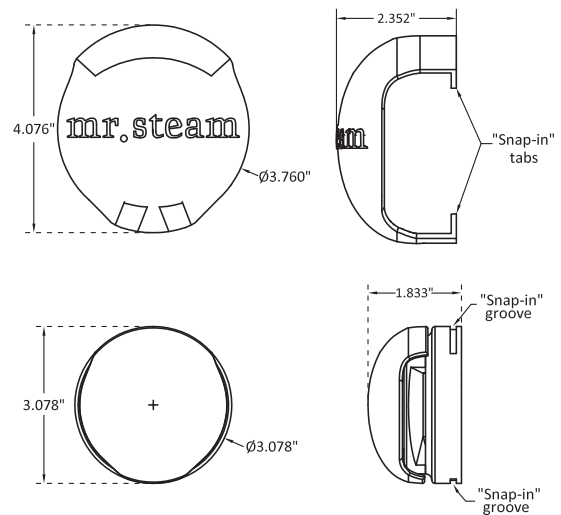

**FOR ILLUSTRATIVE PURPOSES ONLY. IMPORTANT NOTE: FOR SAFE AND TROUBLE FREE INSTALLATION** Before installation, visit [mrsteam.com](http://mrsteam.com) to download the Installation, Operation and Maintenance Manual or refer to the manual provided with the unit.

# CU Blowdown Valve

Part Number: CU81600-1, 2, 3

Water quality can affect efficiency or result in boiler damage if neglected. Boiler feedwater contains impurities in solution and suspension. These impurities concentrate in the boiler. The concentration of these impurities increases as more feedwater is introduced into the boiler and steam is produced. If the suspended solids are allowed to concentrate beyond certain limits, a deposit or "scale" will form on the boiler internal surfaces. This deposit can interfere with the proper boiler operation and cause boiler failure.

The concentration of these impurities is generally controlled by the feedwater quality and by blowdown. Blowdown refers to removing a portion of the boiler water with high solids concentration and replacing it with makeup water of a lower concentration.

**CAUTION** To maintain safe operation of the Blowdown Valve make sure all pipes succeeding the valve are rated to operate with hot water and are properly insulated. To adhere to National and local plumbing and building codes a ASME code blowdown separator tank may need to be installed.

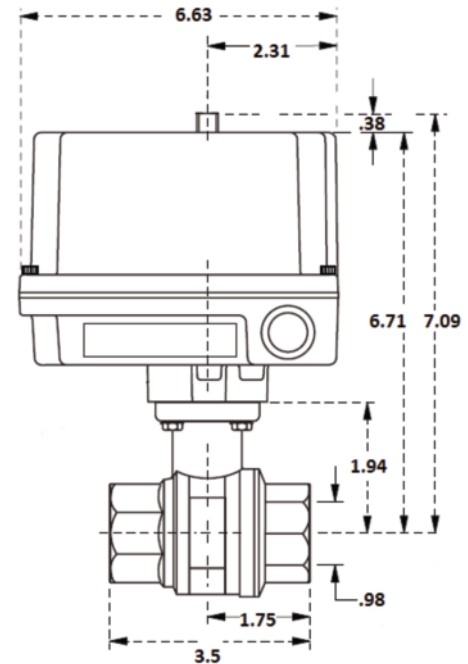

## Operation

The blowdown valve is used in conjunction with the blowdown timer. The blowdown timer is to be wired to the valve in accordance with the procedure explained in the Boiler Installation, Operation and Maintenance Manual (PUR 100376).

## Technical Data

- 1" NPT Valve Size
- Triple Stem Seal Design
- Stainless Steel Valve Body
- NTP Threaded Ends to ANSI B2.1
- Internal Blow-Out Proof Stem
- Meets WW-V-35 Design Specifications
- 115 VAC, 60Hz, 1 PH
- Thermal overload protection
- Temperature Range: -40°F - 150°F
- CSA Certified
- .55 Locked rotor Amps
- Cast Aluminum casing with stainless steel output shaft and fasteners

**FOR ILLUSTRATIVE PURPOSES ONLY. IMPORTANT NOTE: FOR SAFE AND TROUBLE FREE INSTALLATION** Before installation, visit [mrsteam.com](http://mrsteam.com) to download the Installation, Operation and Maintenance Manual or refer to the manual provided with the unit.

# Steam Solenoid Valve

The Solenoid Valve is used to provide Steam-On-Demand® for consistent room temperature comfort and control. It's connected to the CU Steam Generator's control circuit. It opens to release steam from the CU Steam Generator to steam room when Digital-1 sensor detects steam room temperature within set operating temperature range.

### Steam Solenoid Valve Installation:

The steam solenoid valve is powered by the CU Steam Generator control circuit.

The steam solenoid valve:





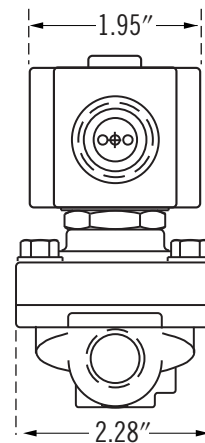
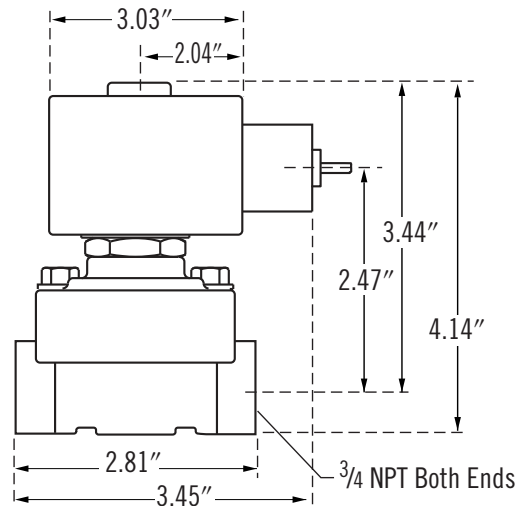

- Should be plumbed as close as practical to the steam room
- Must be installed outside the steam room
- Must remain accessible for service
- Shall be plumbed horizontally

### Technical Data:

- Brass Body
- Normally closed
- 3/4" NPT Pipe size
- 120 VAC
- Max Temperature: 300°F
- Max Operating Pressure Differential: 50 PSI
- Watertight Coil Enclosure



**FOR ILLUSTRATIVE PURPOSES ONLY. IMPORTANT NOTE: FOR SAFE AND TROUBLE FREE INSTALLATION** Before installation, visit [mrsteam.com](http://mrsteam.com) to download the Installation, Operation and Maintenance Manual or refer to the manual provided with the unit.

MODEL	VOLTAGE	PHASE*	OPTIONAL COMPONENTS	SUB OPTIONS
<input type="checkbox"/> C0360	<input type="checkbox"/> 208	<input type="checkbox"/> 1-Single	 <input type="checkbox"/> AromaFlo Oil Delivery System	<input type="checkbox"/> Eucalyptus Oil <input type="checkbox"/> Lavender Oil
<input type="checkbox"/> C0500	<input type="checkbox"/> 240	<input type="checkbox"/> 3-Three	 <input type="checkbox"/> ASME Code Blowdown Tank	<input type="checkbox"/> Models C0360-C2000 (BDT36) <input type="checkbox"/> Models C2500-4500 (BDT42)
<input type="checkbox"/> C0750	<input type="checkbox"/> 480		 <input type="checkbox"/> Recessed Light	
<input type="checkbox"/> C1000	<input type="checkbox"/> 600		 <input type="checkbox"/> CU SteamStop	
<input type="checkbox"/> C1250			 <input type="checkbox"/> Room Timer	<input type="checkbox"/> Mechanical <input type="checkbox"/> Digital
<input type="checkbox"/> C1400			 <input type="checkbox"/> CU Alarm	
<input type="checkbox"/> C2000			 <input type="checkbox"/> Over Temperature Alarm & Shut Off Device	
<input type="checkbox"/> C2500			<input type="checkbox"/> Transformer 1/4 KVA	<input type="checkbox"/> 240V <input type="checkbox"/> 480V
<input type="checkbox"/> C3000				
<input type="checkbox"/> C4500				

\*Single Phase is only available for Models C0360-C1250

PROJECT INFORMATION	
Location:	Contractor:
Architect:	Submitted By:
Engineer:	Date:
Notes:	

**FOR ILLUSTRATIVE PURPOSES ONLY. IMPORTANT NOTE: FOR SAFE AND TROUBLE FREE INSTALLATION** Before installation, visit [mrsteam.com](http://mrsteam.com) to download the Installation, Operation and Maintenance Manual or refer to the manual provided with the unit.